

eS Series Rear mounting bracket installation instructions

Rear mounting methods

The rear mounting bracket enables the display to be flush mounted from behind the mounting surface.

The method used for mounting is determined by the thickness of the mounting surface.

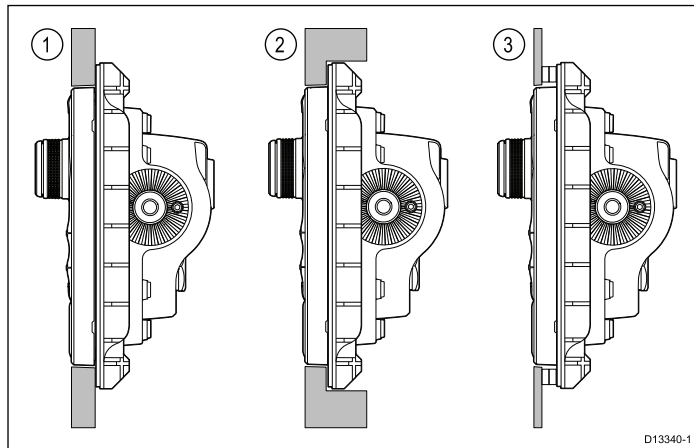

1. Mounting surface and bezel depth are the same (12.5 mm thick) — Recommended
2. Mounting surface is thicker than bezel depth — Precision tools required
3. Mounting surface is thinner than bezel depth — Bespoke installation

The following, additional equipment is required when rear mounting:

- Fixings suitable for securing the bracket to the mounting surface.
- Marine grade sealant
- Shims/washers (required when mounting on a surface that is thinner than the display's bezel depth.)
- Router (required for rebating a thicker mounting surface.)

Caution: Mounting surface requirements

This product is heavy. To prevent potential damage to the product and / or your vessel, observe the following BEFORE installing the product:

- Refer to the weight information provided in the technical specification for this product and ensure that the intended mounting surface is suitable for bearing the weight.
- If the mounting surface is not suitable for the product weight, you may need to reinforce the mounting surface.
- If in doubt, refer to a professional marine equipment installer for further guidance.

Attaching the bracket to the display

To mount the display from the rear, you must first attach the Panel gasket and the Rear mounting bracket to the display.

Ensure both bezel pieces and the menu/home buttons have been removed.

1. Remove the protective backing from one side of the panel gasket (supplied with your display).
2. Affix the gasket to the rear of the display and press firmly onto the flange.

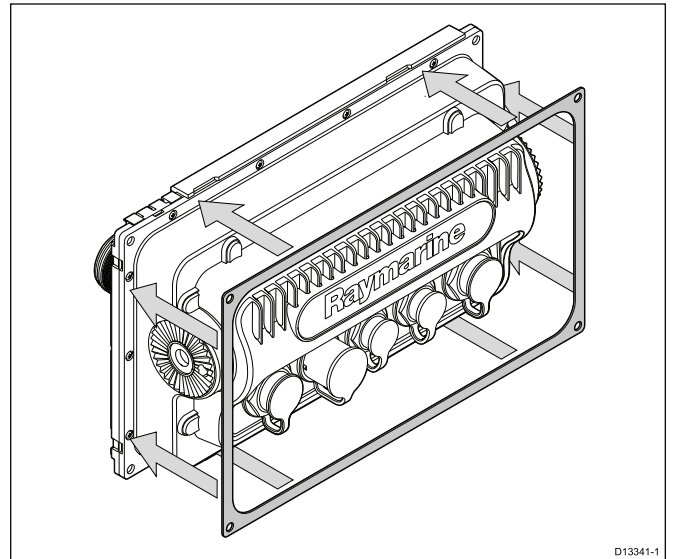

3. Remove the protective backing from the opposite side of the gasket.
4. Slide the bracket over the back of the display, ensuring the fixing holes line up.

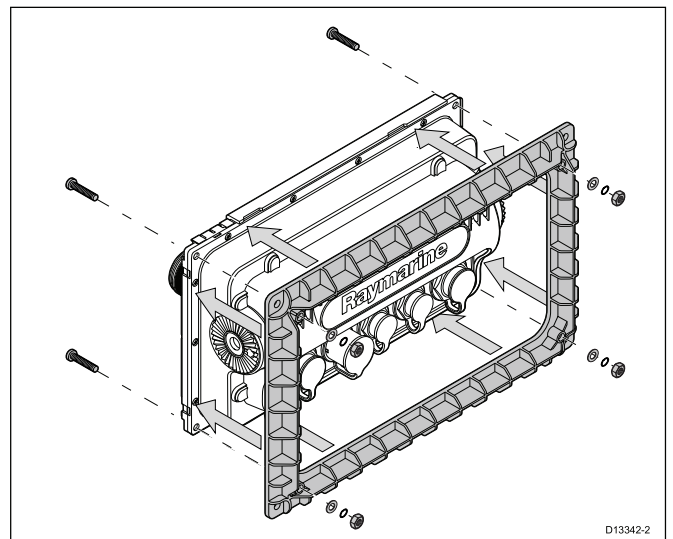

5. Using the fixings supplied with your display, secure the bracket to the display.
6. Refit the menu/home buttons and both bezel pieces.

Note: The panel gasket provides a seal between the unit and mounting bracket. It may also be necessary to use a marine-grade sealant between the mounting bracket and the mounting surface to prevent water ingress.

Rear mounting pre-requisites

Before mounting the display ensure that you have:

- followed the 'Location requirements guidance' found in your product's installation instructions.
- checked the dimensions of your product to ensure there is enough space to install the product from behind the mounting surface.
- checked the chosen mounting surface to ensure that it is deep enough to accept your chosen fixings, without damaging the front of the surface and that it is rigid enough to accept the weight of the product.

Mounting on a surface of the same thickness as the bezel

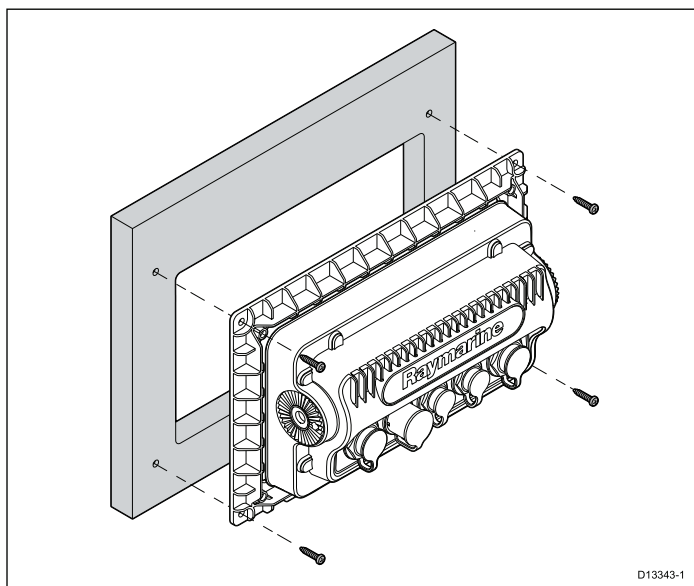

1. Fix the supplied Rear mounting bracket template to the desired location.
2. Using a suitable size drill bit or hole saw (the size and position is indicated on the template), make a hole in each corner of the cut-out area.
3. Cut along the inside edge of the cut-out line indicated on the template.
4. Ensure that the unit fits into the removed area and then remove any rough edges.
5. Secure the product to the mounting surface using your chosen fixings.
6. Connect the power, data and other cables to the product.

Mounting on a surface of greater thickness than the bezel

This type of installation requires the mounting surface to be rebated using a Router.

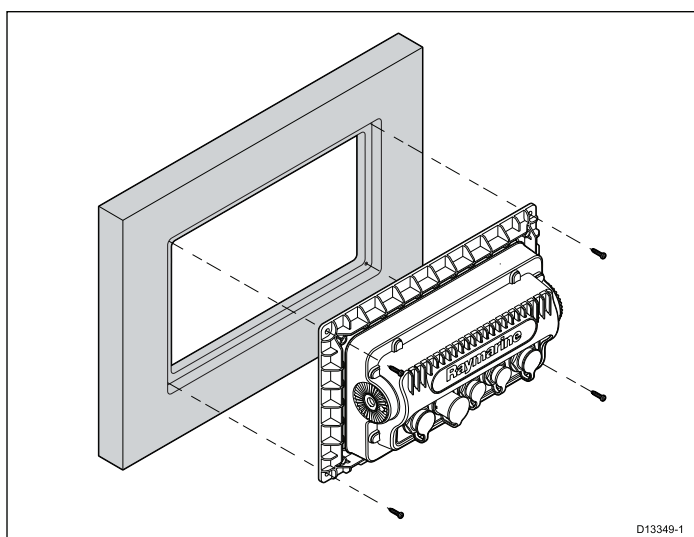

Note: It is recommended that a router be used for cutting and rebating the mounting surface.

1. Fix the supplied Rear mounting bracket template to the desired location.
2. Using a suitable size drill bit or hole saw (the size and position is indicated on the template), make a hole in each corner of the cut-out area.

3. Cut along the inside edge of the cut-out line indicated on the template.
4. Using a Router, follow the rebate line on the template to cut a rebate around the hole to accept the bracket and display assembly.

Note: The thickness of the mounting surface remaining in front of the rebate must be 12.5 mm thick.

5. Ensure that the unit fits into the removed area and then remove any rough edges.
6. Secure the product to the mounting surface using your chosen fixings.
7. Connect the power, data and other cables to the product.

Mounting on a surface that is thinner than the bezel

This type of installation requires bespoke fixings and may also require the mounting surface to be strengthened.

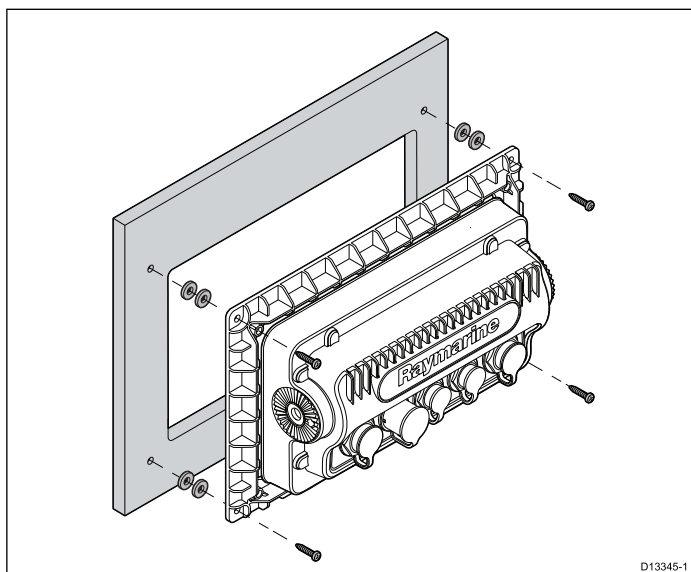

1. Fix the supplied Rear mounting bracket template to the desired location.
2. Using a suitable size drill bit or hole saw (the size and position is indicated on the template), make a hole in each corner of the cut-out area.
3. Cut along the inside edge of the cut-out line indicated on the template.
4. Ensure that the unit fits into the removed area and then remove any rough edges.
5. Secure the product to the mounting surface using your chosen fixings.
6. Connect the power, data and other cables to the product.