



HR600  
HR/C650  
HFF600  
HORIZONTAL WINDLASS



# Contents

<b>Introduction</b>	<b>Page 3</b>
Important Information	
Safe Operation	
<b>Installation</b>	<b>Page 5</b>
<b>Depth of chain locker</b>	<b>Page 6</b>
<b>Handy Hints and Electrical information</b>	<b>Page 7</b>
Circuit breaker	
Deck switch	
Isolating switch	
Batteries	
Rotation	
Solenoid Installation	
<b>Wiring Layout</b>	<b>Page 8</b>
<b>Troubleshooting</b>	<b>Page 9</b>
<b>Line Care</b>	<b>Page 10</b>
<b>HR600 Operating Instructions</b>	<b>Page 11</b>
<b>HR600 Maintenance &amp; Service</b>	<b>Page 12</b>
<b>HFF600 Maintenance &amp; Service</b>	<b>Page 14</b>
<b>HFF600 Operating Instructions</b>	<b>Page 16</b>
<b>Drawings</b>	
Electrical	Page 17
Exploded View of <b>HR600</b>	Page 18
Exploded View of <b>HFF600</b>	Page 19
Exploded View of <b>HRC 650</b>	Page 20
Exploded View of <b>HR 650</b>	Page 21
<b>GYPSY OPTIONS</b>	<b>Page 22</b>
<b>Maintenance Schedule</b>	<b>Page 23</b>
<b>Warranty</b>	<b>Page 24</b>



## INTRODUCTION

Thank you for purchasing a Muir Windlass. Muir go to great lengths to develop anchoring systems that not only meet all your performance and safety requirements, but at the same time designed with a style and finish that enhances the aesthetics of your vessel. With Muir's commitment to quality and use of superior materials and processes we know you will be pleased with your investment, and rest assured that through the correct installation, operation and maintenance your new Muir Windlass will give you years of reliable performance.

## SIGNAL WORDS

### WARNING:

The signal word **WARNING** indicates a dangerous situation that, if not prevented, can lead to a severe injury or death.

### CAUTION:

The signal word **CAUTION** indicates a dangerous situation that, if not prevented, could directly lead to or result in damage to or destruction of the equipment.

## IMPORTANT INFORMATION

**CAUTION:** To avoid damage to the gear drive, windlass or vessel when bringing the anchor up hard, it is a preferred practice to mark the chain at approximately 5-meter intervals from the anchor, to alert the operator to the anchor position. Alternatively, an Auto Anchor can be used.

**CAUTION:** Windlasses and mooring capstans must have pressure relief valves installed in the case of a hydraulic drive or an appropriate capacity circuit breaker in the case of an electric drive.

**CAUTION:** If anchor retrieval is impaired by high wind, heavy seas or the anchor is snagged, ease the load by either motoring or sailing slowly forward into the wind.

**WARNING:** Warranty will be voided if the vessel lays directly on the anchor windlass without a chain stopping device engaged.

**WARNING:** Under no circumstances should the windlass be operated if it is stalled or overloaded.

## SAFE OPERATION

Read all safety instructions and information. Failure to comply with safety instructions and information may lead to property damage, serious injuries, or death.



BUILT TO LAST SINCE 1968 3



## COMPACT SERIES – LYNX HR/C650 H600 HFF600

### INTENDED USAGE

This product is exclusively intended for the application as an anchor winch and as agreed on the time of delivery. Any other or extended form of use does not comply with this definition of intended use.

The intended use includes compliance with this documentation and other applicable documents to avoid malfunctions and damage in operation.

The product in its delivery status is safe to operate. However, the product may pose dangers if improperly used by unauthorized, untrained, and uninstructed staff or if not used according to its intended use.

### GENERAL SAFETY NOTES

The anchoring systems are very high load bearing and extremely powerful pieces of mechanical equipment. Extreme caution must be taken when operating these systems, and only trained personnel who have reviewed this manual shall be permitted to use them.

Key safety risks include, but are not limited to:

- Crush points between highly loaded chain and the equipment
- Entanglement in rotating equipment (capstan, gypsy/ chainwheel etc.)
- Impact risks from chain whip due to uncontrolled chain release through improper use of the windlass.
- Impact risks from chain whip due to misaligned equipment.

**WARNING: Failure to review and abide by this document for the correct installation, commissioning, operation, and maintenance of the equipment will increase the likelihood of the above risks.**

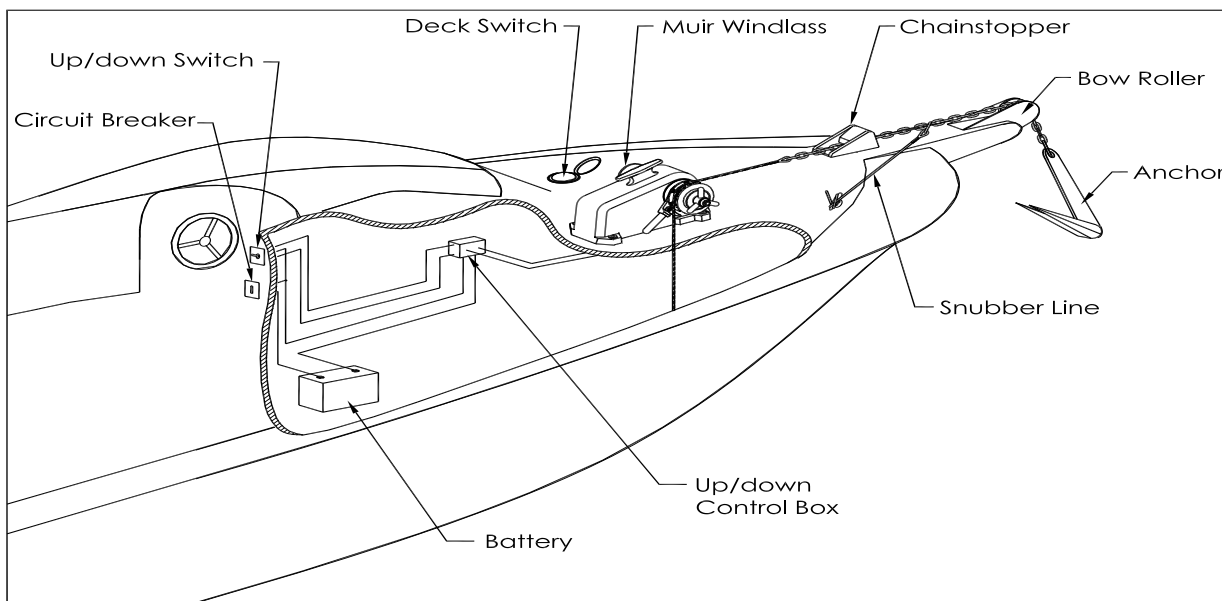

Note that figures might deviate from the product and are not drawn to scale. No conclusions can be drawn with regard to size and weight.



BUILT TO LAST SINCE 1968 4



## INSTALLATION

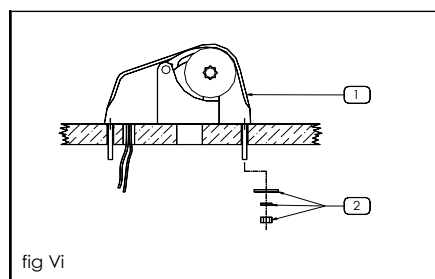
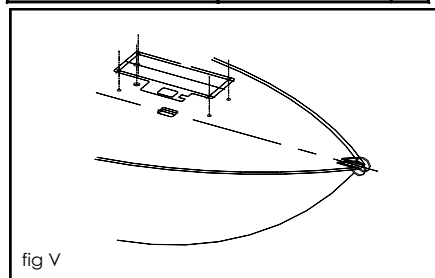
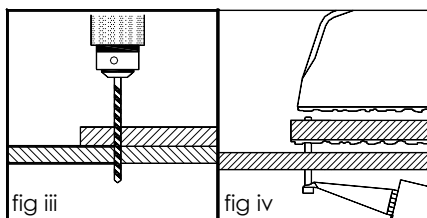
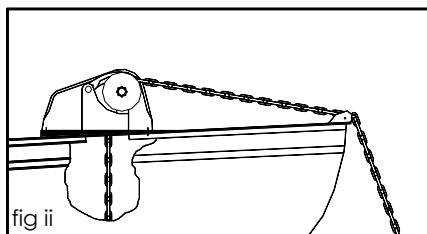
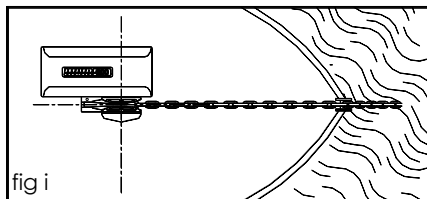

**Figure(i)** Locate the windlass centrally fore and aft using the supplied deck template or windlass base plate. Check that the chain leads unhindered to the anchor roller. The chain leads onto the starboard side of the gypsy, wraps around at least 120° and falls below deck through the chain pipe (hawser). Ensure there is sufficient room around the windlass to allow full rotation of the windlass manual/clutch handle (if supplied).

**Figure (ii)** The centre of the gypsy must be in the same plane as the chain lead from the bow roller. If the deck is angled (fore & aft) or curved (port to starboard) a suitably shaped mounting block will be required to spread the load evenly over the deck surface and mount the windlass base on a level and even footing. The chain must achieve a **120 degree wrap** around the gypsy to ensure smooth operation. A Muir fairlead roller can be installed if required to ensure this wrap is achieved.

**Figure (iii)** Place the shaped mounting block (if required) onto the deck. Using the layout template supplied, mark the mounting centres and drill the holes, (Refer template).

**Figure (iv)** Apply an appropriate sealant (e.g. Sikaflex 271) to the base plate and mounting block (if required) and carefully tighten the nuts & washers onto the threaded studs under the deck. Remove excess sealer.

For Aluminium or Steel hull vessels, it is important to insulate the windlass with a non-conductive gasket to avoid corrosion. This also applies below deck with the mounting bolts, nuts and washers. Where the deck construction is light or of foam sandwich construction, a plywood stiffener of at least 16mm (5/8") should be fitted to the underside of the deck to spread the load and to prevent the bolts from pulling through the deck. Large diameter washers on the underside of the stiffener assists to spread the load.

### Figure (v and vi)

1. First placing the supplied windlass base plate on the deck, then lower then windlass into the precut and drilled holes in the deck.
2. From below, place washers and nut on each stud and tighten.

NOTE: On assembly, grease all moving parts and deck plate grease nipple with a Lithium/teflon based grease. The Motor/geardrive assembly should be protected with anti-corrosion film or grease tape.

## DEPTH OF THE CHAIN LOCKER

Measuring the vertical distance (minimum fall) underside of the deck and the top of the completely stored and heaped anchor rode in the locker will assist in determining the installation to suit your vessel. Refer to the fall depth diagrams to the left, and the options detailed below. It is also recommended that the chain be directed to the center of the chain locker.

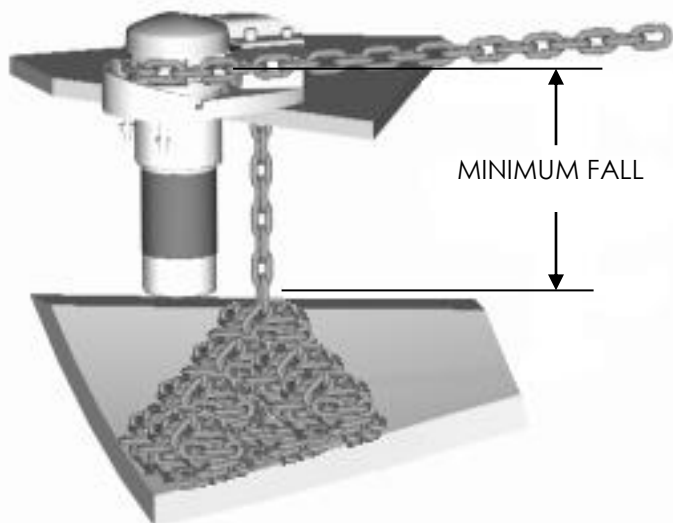

### Vertical Windlass:

The running gear, gypsy and capstan are positioned above the deck with the motor and gear drive below. Vertical windlasses operate at best with greater anchor rode fall than the horizontal windlass and a minimum fall of 300mm from top of stacked anchor rode is recommended. This is particularly important if using nylon line, which does not fold and stack as well as chain. Vertical windlasses minimise deck intrusion and the modern curved lines of the Muir windlass enhance the look of any vessel. A vertical windlass provides the advantages of a 180-degree wrap of the anchor rode around the gypsy.

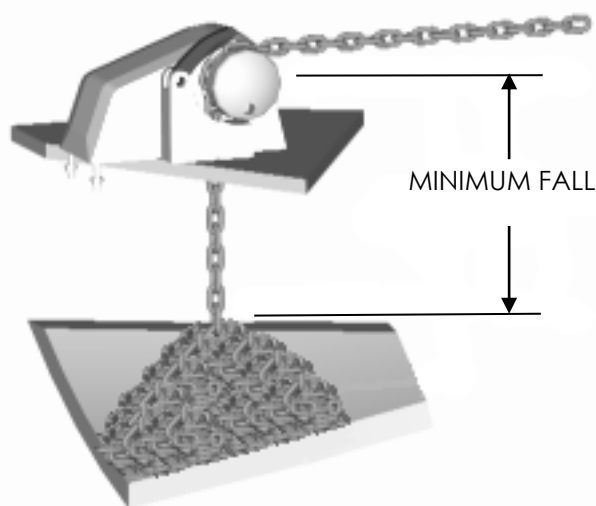

### Horizontal Windlass:

Fully enclosed, above deck, this style is usually preferred where locker space is limited, or additional fall is required. The motor and gear drive are fully enclosed in the housing with nothing protruding below deck. The horizontal windlass operates with optimum anchor rode fall of at least 300mm from the top of the stacked anchor rode, and due to the horizontal orientation of the gypsy higher above the deck there is additional fall provided. These units are ideally suited for vessels with less locker space.

Vertical Windlass Model	Horizontal Windlass Model	Minimum Fall (Dist. Top of Pile)
VR/C600, VFF600	HR600 – 700, HFF600 - 700	300 mm
VR/C850 – 2200, VFF1050 - 2200	HR1200 - 1600	450 mm
VR/C 2500 - 3500	HR2500 - 3500	650 mm
VR/C 4000	HR4000 - 4200	800 mm



## HANDY HINTS

It is a common mistake to locate the windlass too far forward, or too close to the bulk head, where there is insufficient room for chain and anchor stowing. The chain fall position should be in the centre of the chain locker. If the chain falls alongside a bulkhead or onto the stem it will pyramid and jam.

If the chain falls into an undesirable position, a metal tube can be fitted under the hawser to redirect the chain to a preferred position. This pipe should be at least 1 ½ times the width of the chain. It should also have as much vertical angle as possible. Position the windlass in the best location with the chain hawser facing forward. Ensure sufficient room to run electric cables to the windlass. Follow the instructions on page 4 including underdeck stiffening, deck camber, alignment, mounting blocks and sealing procedures.

## ELECTRICAL

See Wiring Diagrams for wiring instructions.

**WARNING: INCORRECT WIRING CAN LEAD TO FAILURE OF WINDLASS AND SEVERE INJURY OR DEATH DUE TO POTENTIAL FIRE HAZARD.**

### Circuit breaker (must be fitted to ensure warranty)

If the windlass is overloaded or stalled the circuit breaker automatically cuts off power to the windlass and protects the wiring and motor. The circuit breaker should not be used as an isolating switch, purely for safety reasons.

**Deck Switches** are best located out to either port or starboard or directly behind the windlass in a position where it can be easily reached with your foot or knee, preferably where you can view the anchor and chain coming aboard.

**Isolating Switch** should be fitted in an accessible position for safety, ideally close to the battery or switches. The isolating switch is not a circuit breaker.

**Batteries** are best located as close to the windlass as possible. Larger cables will reduce the voltage drop to the motor and the heat generated when running the windlass. Small diameter cables drop voltage considerably. Use the following table as a guide to your required wire size:

Distance from battery to motor (m)	Cable Size		Cable Diameter (mm)
	(mm <sup>2</sup> )	AWG	
7 (23')	25	3	8 (5/16")
9 – 17 (30' – 55')	35	2	10 (3/8")

**Rotation:** Windlasses may be wired for single or dual direction, using single or dual deck switches for raising or lowering. Alternatively a remote control solenoid packages with Toggle Switch, Hand Pendant or Auto Anchors are available.

### Solenoid Installation (Required for Deck Switches)

We recommend that the solenoid is installed in an upright position, where it has minimal exposure to sea water and in close proximity to the electric motor of the windlass.

A Remote Switch may be used with or without a solenoid for the HFF600.

For wiring information, please refer to the appropriate wiring diagram.



**This way up**



**BUILT TO LAST SINCE 1968 7**



TOGGLE SWITCH LAYOUT

1. BATTERY
2. CIRCUIT BREAKER
3. SOLENOID/CONTROL BOX
4. TOGGLE SWITCH

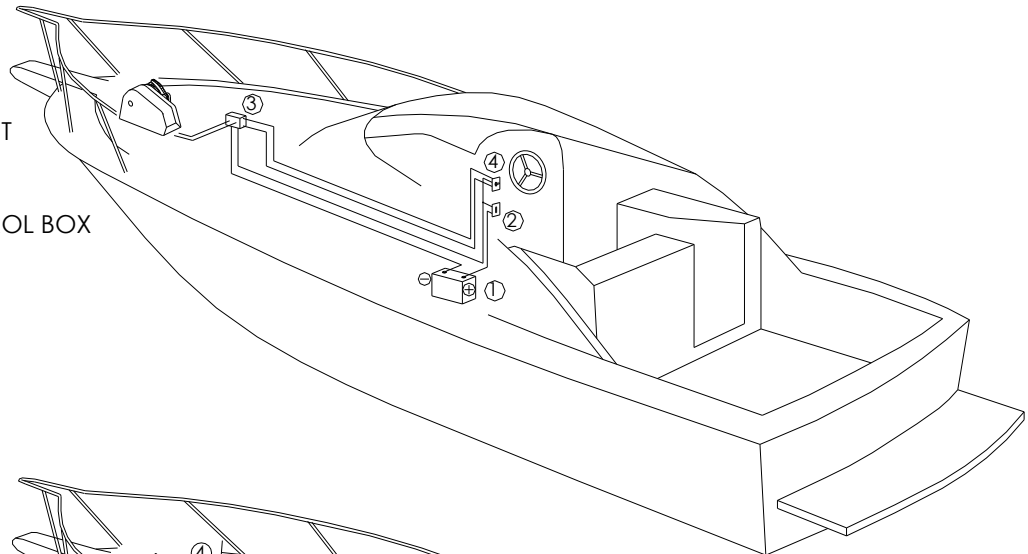

TOGGLE / DECK SWITCH LAYOUT

1. BATTERY
2. CIRCUIT BREAKER
3. SOLENOID/CONTROL BOX
4. DECK SWITCHES
5. TOGGLE SWITCH

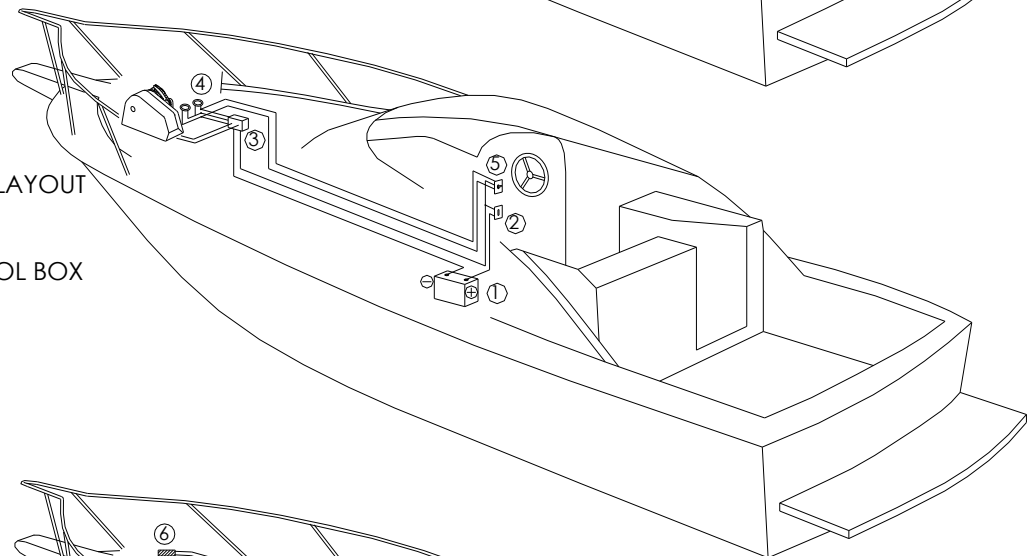

AUTO ANCHOR LAYOUT

1. BATTERY
2. CIRCUIT BREAKER
3. SOLENOID/CONTROL BOX
4. DECK SWITCHES
5. AUTO ANCHOR
6. AUTO ANCHOR SENSOR

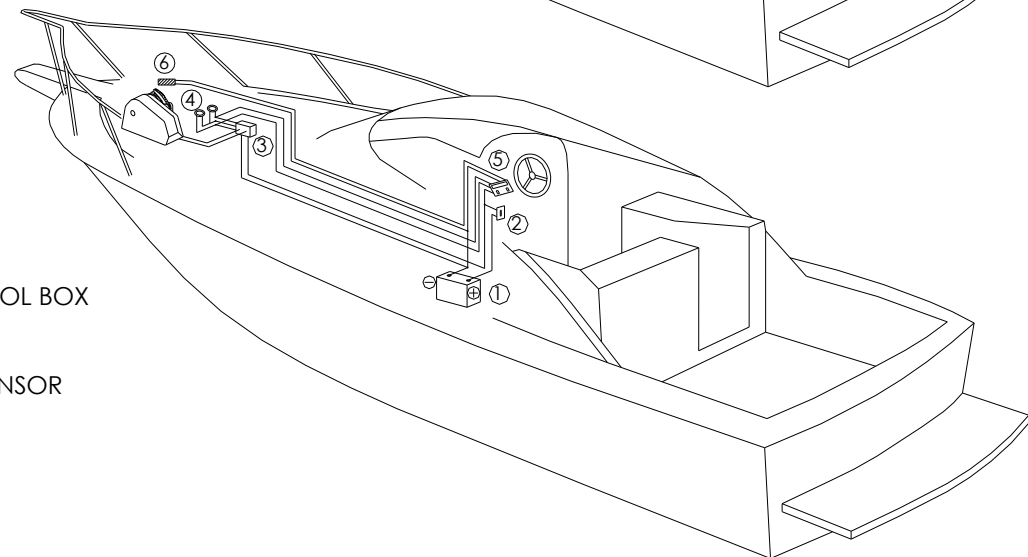

**CAUTION:** NOT TO BE USED AS WIRING DIAGRAMS



BUILT TO LAST SINCE 1968 8





## Trouble Shooting

### ELECTRICAL

1. Check the battery circuit breaker and ensure the isolating switch is on.
2. Check battery is charged up to 12 or 24 volts.
3. Check that the foot switch plunger is contacting.
4. Check remote control solenoid is contacting, if this is clicking the problem may be low voltage a faulty solenoid or a wire not properly connected or tightened.
5. Check wiring between controls, solenoid and motor are intact.
6. If the motor will not turn after checking the above points check that the motor bushes are not worn or sticking.

### MECHANICAL

If the windlass running gear will not turn or operate check the following

1. Check the drive key between the gearbox and motor input.
2. Check the drive key on main shaft to gearbox output.
3. Check that the clutch above the chain gypsy is tightened to the chain gypsy drive using the manual handle supplied.
4. If the line slips check the tension on the finger and increase spring tension.

### HYDRAULIC MOTOR

Refer any problems with your hydraulic motor to a Muir service agent or Muir Hobart.

### FREEFALL MECHANISM

1. Check that the freefall plunger and spring can move freely.
2. Ensure that the declutcher pawl is in the correct position and that the grub screws holding this in place are tightened.



### Line Care

Using the wrong type of line may cause the line to jam causing excessive line wear. Muir Windlasses are designed to run on a 3-strand nylon line (supplied by Muir) which has been specially treated with fabric softener to prevent it from hardening. It is recommended to soak your rope in fresh water containing fabric softener every 3 months.

In case of a rope jam, slacken off the windlass clutch to free the jammed line. When retrieving the anchor rode do not continue to run the windlass if the anchor or chain is jammed, as line slippage in the gypsy will cause damage to the line.

### Rope/Chain Splice.

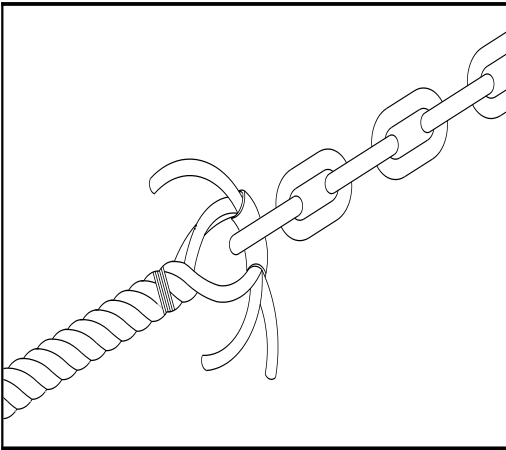

1. To stop rope unravelling, seize rope 400mm(16") from end with whipping twine. Unlay strands.
2. After placing 20mm (3/4") of heat shrink sleeve tubing through the last link of chain, pass one strand of rope through sleeve and chain from one side and the other two strands of rope from the opposite side. (See illustration).
3. While pulling all three strands tight, shrink the sleeve tightly onto the rope using a hairdryer / fan heater or by immersing in boiling water.
4. Remove seizing and complete back splice in normal manner for two full tucks. With a hot knife pare down the three strands by 1/3 and insert two further tucks. Pare down by another 1/3 and finish with two tucks. Cut any remaining tails.

**CAUTION:** POOR SPLICING OF ROPE TO CHAIN WILL LEAD TO REDUCED OR UNACCEPTABLE PERFORMANCE OF THE ROPE CHAIN MANAGEMENT SYSTEM.

## HR/HFF600/HR650

### OPERATING INSTRUCTIONS

**WARNING:** Always keep well clear of the windlass when releasing or retrieving chain and anchor. Keep fingers, hair and clothing well clear when the windlass is in operation, particularly around areas where the chain enters and leaves the gypsy. There is a high risk of crush or entanglement injuries in these areas.

**Manually releasing chain:** To release the anchor rode, place the handle into the clutch drive Bi-square as shown in the diagram at the bottom of the page and turn anti-clockwise to release the clutch brake. Let the anchor fall and control the run of the chain by tightening handle clockwise using the clutch mechanism as a brake.

**Anchoring:** When laying at anchor use a chain stopper, nylon/chain bridle or snubber line to prevent snatching and direct loading on the windlass main shaft.

**CAUTION:** Never use the windlass as a mooring bollard! Always use a snubber line or chain stopper to take the load of the chain off the windlass.

**Retrieving chain:** Before operating the windlass tighten the clutch with the handle in a **clockwise** direction, then remove the handle. If the anchor is buried hard, secure the line to take the load off the windlass and motor forward to pull the anchor free.

**Electric operation:** Releasing and retrieving the Anchor rode is identical when operating the windlass. To release the anchor down, reverse the motor by pushing remote switch to “down” which drops the chain and the anchor immediately. When the anchor is at the desired depth, the windlass can be stopped by letting go of the switch, the chain and rope can then be lowered further by releasing the manual clutch.

**Anchor Launching:** If the anchor roller can be positioned so that the anchor falls as soon as the windlass is reversed, the whole operation can then be carried out remotely. Remote switching controls are self-centering and stop the windlass when the switch is released. Mark the anchor end of the line at 2 and 5 metre (6.5' & 16.5') intervals to enable the operator to judge when the anchor is almost up.

**CAUTION:** Go slowly for the last few metres of retrieval by letting go of the switch, rather than waiting for the anchor to fly up over the roller and pull tight, this will put excessive load onto the bow roller, windlass and fore deck so should be avoided.

### SERVICING

The gear drive is filled and sealed at factory with long life synthetic oil and does not require regular replacement. Rinsing all deck gear with fresh water after every excursion ensures that salt deposits and corrosion are kept to a minimum. We recommend the windlasses of Pleasure Vessels are stripped yearly and all moving parts cleaned and greased with a Marine Grease, Teflon or Lithium based grease (e.g. Shell Gadus S220). In the case of Work and Charter Vessels we suggest it is carried out more frequently.



# HFF/HR600/HR650

## Maintenance & servicing

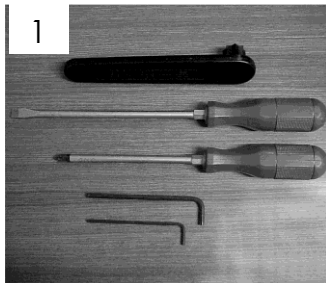

1. You will require the following tools to complete this procedure:

- (i) Clutch handle
- (ii) Screwdriver (flat blade)
- (iii) Screwdriver (Philips head)
- (iv) Allan key 3/16"
- (v) Allan key 1/8"



2. Start by placing the clutch handle into the **Clutch Caps 'A'** (bi-square), then turning it anti clockwise to move the clutch nut. (As seen in 3.)

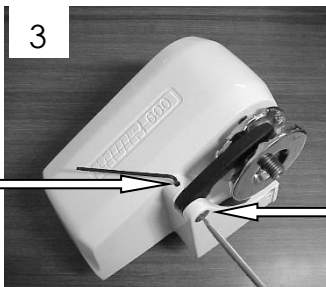

3. Place flat bladed Screwdriver into the spring-loaded **Finger Pin 'B'** and hold firmly. Then release **Grub Screw 'C'** by turning anti clockwise. Now the tension on the Finger Pin can be released by gently turning the Finger Pin anti clockwise.

*Note: upon reassembly don't over tension the **Finger Pin 'B'**. A 1/4 turn in the clockwise direction should be adequate.*

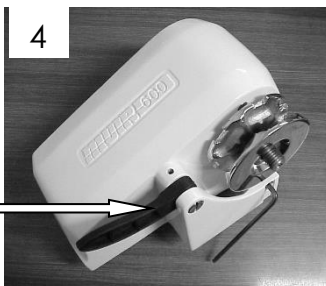

4/4a. With **Rope Finger 'D'** out of the way. Now remove the **Cross Recessed Screw 'E'** by turning it anti clockwise. For HR/C 650, the SS316 cast peeler, which replaces the H600 band peeler, is similarly removed by unfastening the two M5 SHCS bolts located at position E.

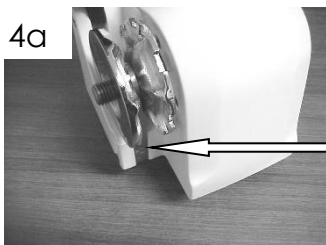

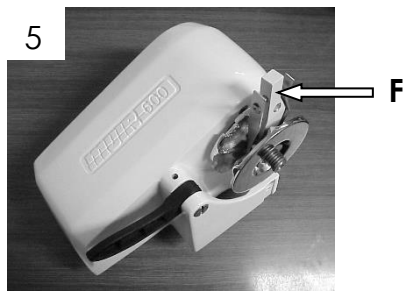

5. To remove the **Gypsy 'G'** (chain wheel/wildcat) rotate **Peeler & Stripper 'F'** as shown. This is not required for the HR/C650 as the peeler will fall away from the **Gypsy 'G'**.

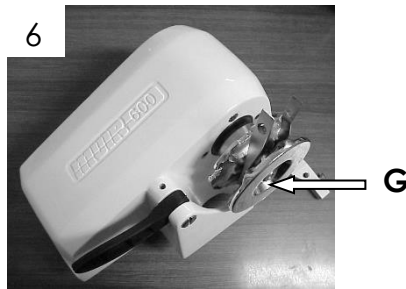

6. Then slide **Gypsy 'G'** off the main shaft.

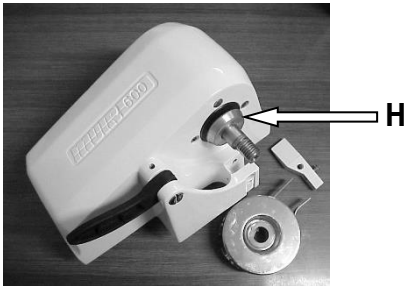

7. Now these parts can be exchanged as required.

**Please note:**

Before reversing the above steps to reassemble the windlass, it is recommended that the exposed **Main shaft & Cone 'H'** be generously coated with a Lithium/Teflon based grease.

## HFF600

### Maintenance & Servicing



1. You will require the following tools to complete this procedure:

- (i) Muir Clutch handle (P/N. F90-HANNYL0600)
- (ii) Flat blade screwdriver
- (iii) Phillips head screwdriver
- (iv) 3/16" Allen key
- (v) 1/8" Allen key
- (vi) A Lithium/Teflon based marine grease.
- (vii) HFF 600 Exploded view Dwg. K08-FREHFF600

2. **Removing Declutching Pawl** (P/N. P13-PWL316HFF600) & SHC Screw (P/N. S45-30406.35019). Place 3/16" Allen key into (A) SHC Screw and turn anti-clockwise to remove. Now the Declutch can be removed.

- 3a. **Removing Clutch Nut** (P/N. P07-CLNBRZHFF600), SHC Screw (P/N. S45-30406.35013) & Retaining Washer (P/N. P21-304019.2007.012). Place 3/16" Allen key into (B) SHC Screw and turn anti-clockwise to remove.

- 3b. Now place the Clutch Handle (P/N. F90-HANNYL0600) into (C) bi-square and turn anti-clockwise to remove.

*Note: After Declutcher and retaining washer has been removed the clutch can now be engaged and disengaged manually (if required).*

4. **Releasing Finger** (P/N. R40-FGRPVC0600A). Place 1/8" Allen key into (D) Grub screw (P/N. S35-3040635006) and turn anti-clockwise to release. With the tension released from the finger it can be pivoted out of the way.

*Note: upon re-assembly don't over tension the Finger Pin (P/N. P15PIN30415.88X41). With line removed from the gypsy, place Screwdriver (flat blade) into slot (E) and turn it a ¼ turn in the clockwise direction then hold. Now place 1/8" Allen key into (D) Grub screw and turn clockwise to tighten.*

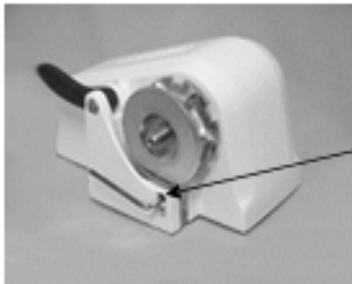

F

**5a. Removing Peeler** (P/N. P05PLRALL0600C) & Stripper (P/N. P19-STR3040600C). Place 3/16" Allen key into [F] SHC Screw and turn anti-clockwise to remove.



G

**5b.** Now place Screwdriver (Phillips head) into [G] and turn anti-clockwise to remove. Now the Peeler & Stripper can be removed.

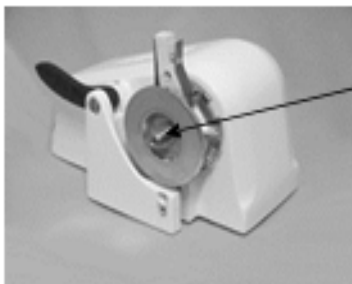

H

**6. Removing Gypsy** (P/N. P10-F06008C). The Gypsy can now be taken off the main shaft (H).

*To complete the service or replacement of parts reverse the above steps.*

**Note:** We recommend the use of Lithium/Teflon based grease.

- Before re-assembly, grease the exposed Main Shaft/Cone (I) & Gypsy bore (J).



I

### Line Care

Using the wrong type of line may cause the line to jam and give excessive wear of the line. Muir Windlasses are designed to run on 3-strand nylon line (supplied by Muir) which has been specially treated with fabric softener to prevent it from hardening up. It is recommended to soak your rope in fresh water every 3 months with fabric softener.

In case of a rope jam slacken off the windlass clutch to free the jammed line. When retrieving the anchor rode do not continue to run the windlass if the anchor or chain is jammed. as line slippage in the gypsy will cause damage to the line.



# HFF600

## OPERATING INSTRUCTIONS

The concept of the Free Fall windlass is to deploy and freefall an anchor remotely from the helm station.

1) Engaging the down switch or reversing the windlass automatically releases the clutch released allowing the chain gypsy to free wheel thus launching the anchor.

2) Engaging the up switch of the windlass will automatically tighten the clutch allowing the winch to take up any slack in the anchor rode.

**WARNING: This must be done only when the anchor and all the rode have touched the bottom and not whilst in freefall.**

3) Then release the switch when sufficient slack in the anchor rode has been taken up.

4) To retrieve the anchor, operate the winch in the up direction. It is also recommended that the vessel is motored into the wind / towards the anchor rode to minimize excessive load on the windlass.

5) If necessary, the windlass can be powered down without freefall, this can be done by removing the Declutching Pawl (see *Maintenance and servicing step 2 Page 9*).

6) The clutch can also be operated manually after the above step has been performed. The clutch **has a right-hand thread**, so to release the clutch insert & turn the handle (see *item 30 of exploded view K08-FREHFF0600*) in an anti-clockwise direction. To tighten turn the handle in a **clockwise direction**.

7) For the efficient operation of the windlass to periodically **apply grease to the Declutching Pawl** (see *item 25 of exploded view K08-FREHFF0600*) located on top of the chain pipe.

8) The RCMS Nylon Finger (P/N. R40-FGRPVC0600A) applies pressure to the line and splice and must be tightly tensioned onto the gypsy without line fitted by releasing the grub screw (P/N. S35-30406.35006) and adjusting the finger pin (P/N. P15-PIN30415.88X41) by tightening Anti Clockwise. Refer to Figure 3 and follow instructions in the Maintenance and Servicing Section on page 11.

**WARNING: IT IS NECESSARY TO INSTALL AN ISOLATION SWITCH AS WELL AS A CIRCUIT BREAKER TO THE FREEFALL WINDLASSES TO ISOLATE THE WINDLASS WHEN NOT IN USE. This is to prevent the rope and chain from playing out if the winch is accidentally reversed.**





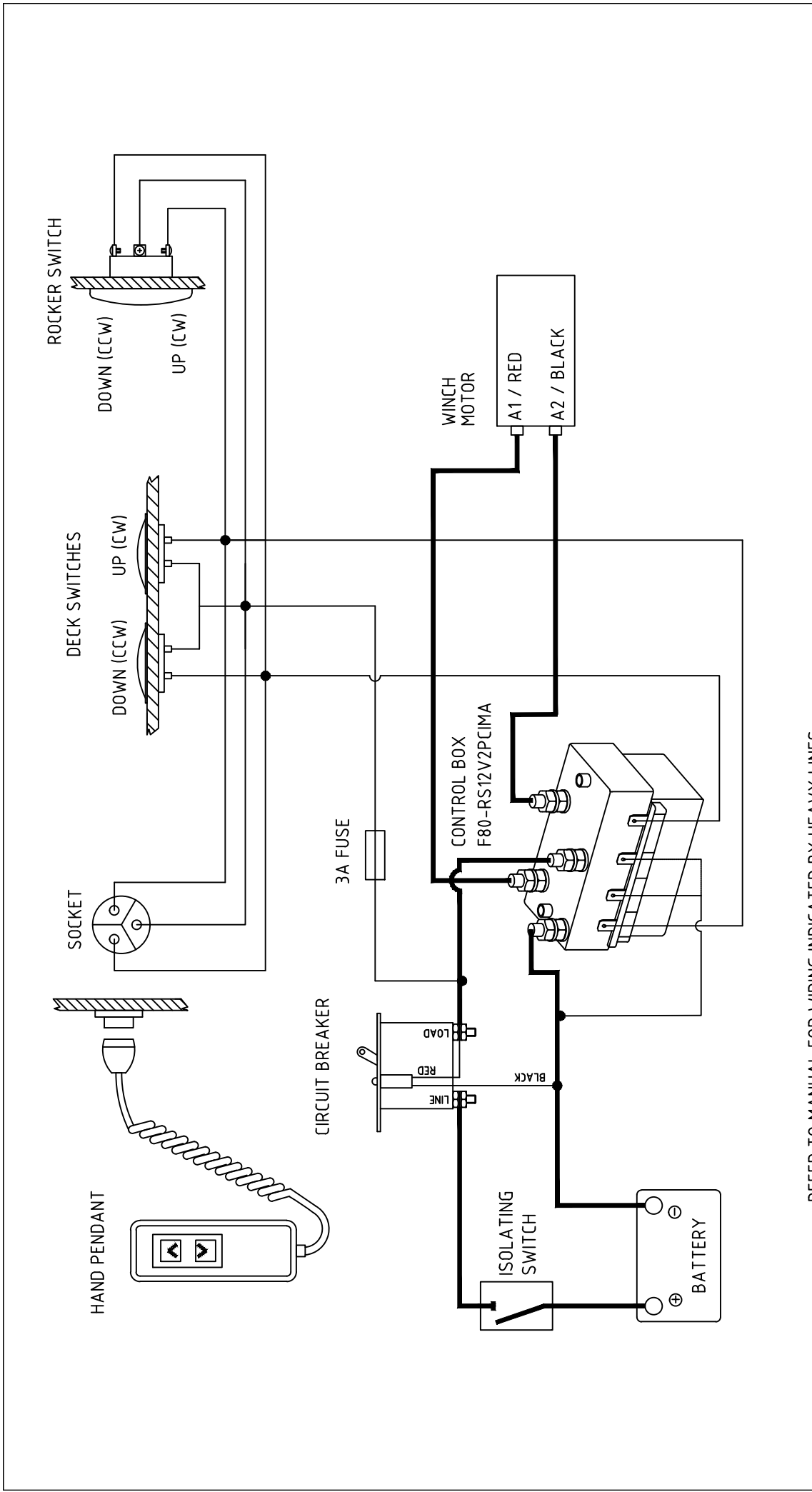

**—** REFER TO MANUAL FOR WIRING INDICATED BY HEAVY LINES  
**—** LIGHTER LINES INDICATE LIGHT WIRING.  
**- - -** DASHED LINES INDICATE OPTIONAL WIRING.

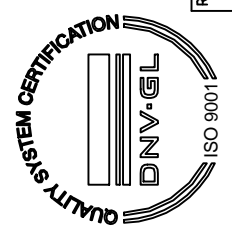

MOTOR 12/24V	200/4.00W	600W
--------------	-----------	------

REV No. 02  
 DESC. NC.# 1526

BY: BW  
 DATE: 20/08/18

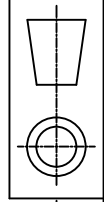

TOLERANCES (mm)	
X.	±
X.X	±
X.XX	±
UNLESS OTHERWISE SPECIFIED	
MATERIAL	
FINISH	

<b>muir</b> WINDLASSES AUSTRALIA	
TITLE	TWO TERMINAL MOTOR (REVERSING) WIRING DIAGRAM (POSITIVE ACTING SOLENOID)
PART No.	WIRE-600
DRN	MW
DATE	8/12/14
DRG No.	CIMA SOLENOID
SCALE	NTS
APP1	WIRE-600
APP2	
SIZE	A4
© COPYRIGHT MUIR ENGINEERING PTY. LTD.	

ITEM	PART NUMBER	DESCRIPTION	QTY
1	P22-HSGHFF600	HOUSING ALLOY HFF600 FREEFALL	1
2	K06-SFTH00600C	SHAFT ASSEMBLY H600 COMPACT	1
3	P24-STD3040600C	STUD SS304 H600C	4
4	S76-30407.94	WASHER SPRING SS304 5/16 INCH	4
5	S20-30407.94	NUT HEX SS304 0-5/16 INCH	4
6	R41-ORG02502201.8	O' RING SEAL 1 X 7/8 X 1/16" (BS020)	1
7	R42-SEA052022.207.9	SEAL 52 X 22 X 8 (TC12828)	1
8	S45-30406.35013	D' WASHER SS316 - 1 1/4" X 3/4" X 4MM	1
9	P23316031.8019.104	SCREW SHCS SS304 1/4 INCH X 0-1/2 INCH	1
10	S34-30404.76025	SCREW CSK X-R MT 304 0-3/16 X 1 INCH	2
11	P19-STR3040600C	STRIPPER SS304 H600C	1
12	S45-30406.35025	SCREW SHCS SS304 1/4 INCH X 1 INCH	1
13	P05-PLRALL0600C	PEELER ALLOY H600C	1
14	P22-BPLALLH00600	BASE PLATE ALLOY H600 COMPACT	1
15	S45-30406.00025	SCREW SHCS SS304 6MM X 25MM	4
16	P15-PIN30415.88X41	PIN FINGER SS304 H600C	1
17	S36-SPR304FGR0600C	SPRING FINGER H600C	1
18	R40-FGRPVC0600A	FINGER PVC VR/C600A	1
19	S33-30404.76013	SCREW CSK SL MT 304 0-3/16 X 0-1/2 INCH	4
20	S35-30406.35006	SCREW GRUB 304 0-1/4 X 0-1/4 INCH BSW	1
21	P21-304025.006.403	WASHER 304 25MM X 1/4" X 1/8"	1
22	R44-PLG25H600C	PLUG H600C	1
23	P07-CLNBRZVR00600A	CLUTCH NUT BRONZE VR600A	1
24	F90-HANNYL0600	HANDLE NYLON CLUTCH 600	1

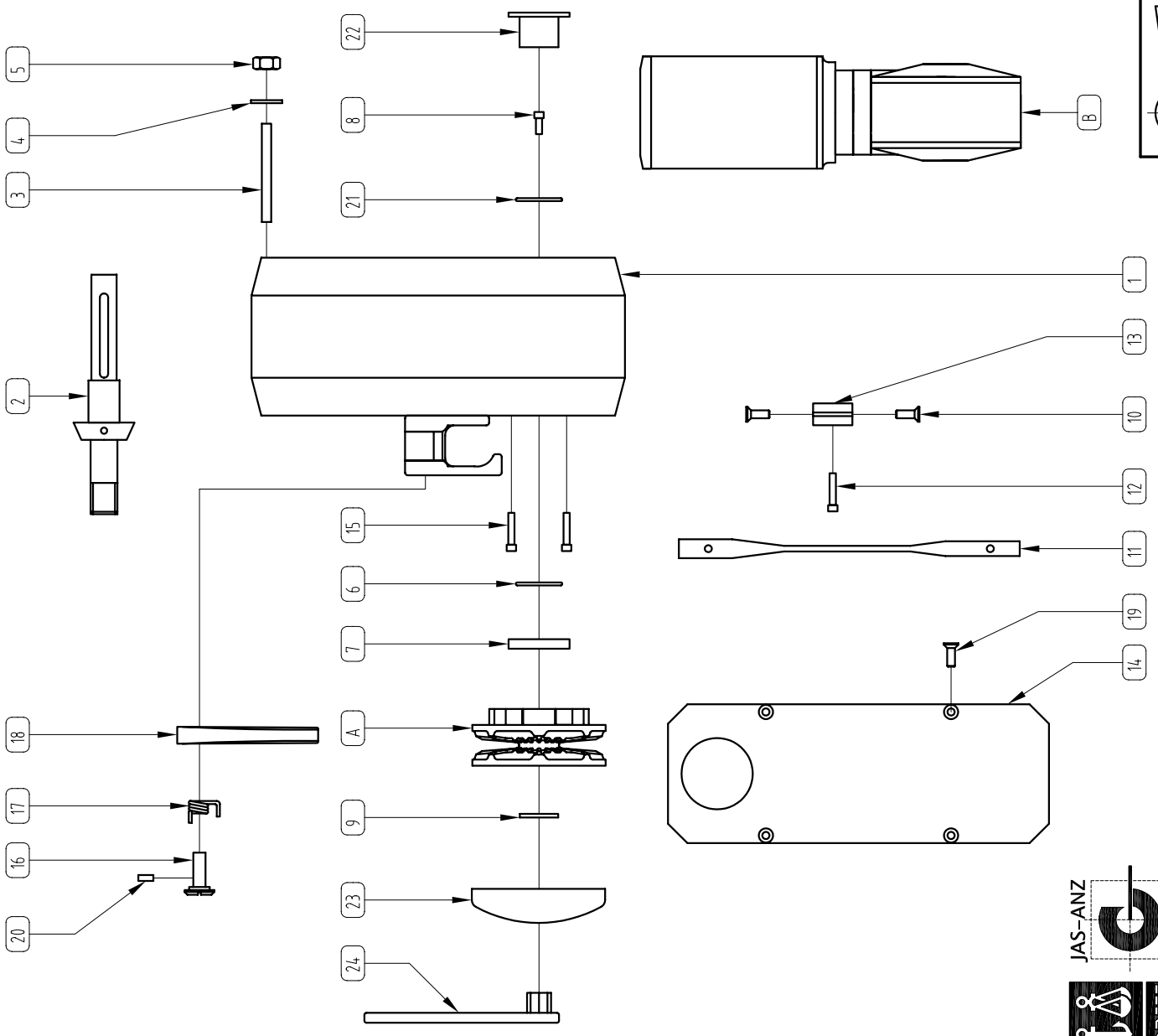

A: GYPSY  
B: MOTOR / GEARBOX ASSEMBLY

**WINDLASSES AUSTRALIA**

**HR600 COMPACT / SINGLE GYPSY**  
**EXPLODED VIEW**

PART No. K08-COMHR0600

DRN: AJN    DATE: 05/04/00    DRG No. K08-COMHR0600

SCALE: NTS    APP1:    APP2:    SIZE: A4

© COPRIGHT MUIR ENGINEERING PTY. LTD.    2

TOLERANCES (mm)

X. ±  
X.X ±  
X.XX ±

UNLESS OTHERWISE SPECIFIED

MATERIAL

FINISH



REV No. 5  
DESC. CR #1154 ITEM 9 UPDATED

BY MW  
DATE 12/01/15

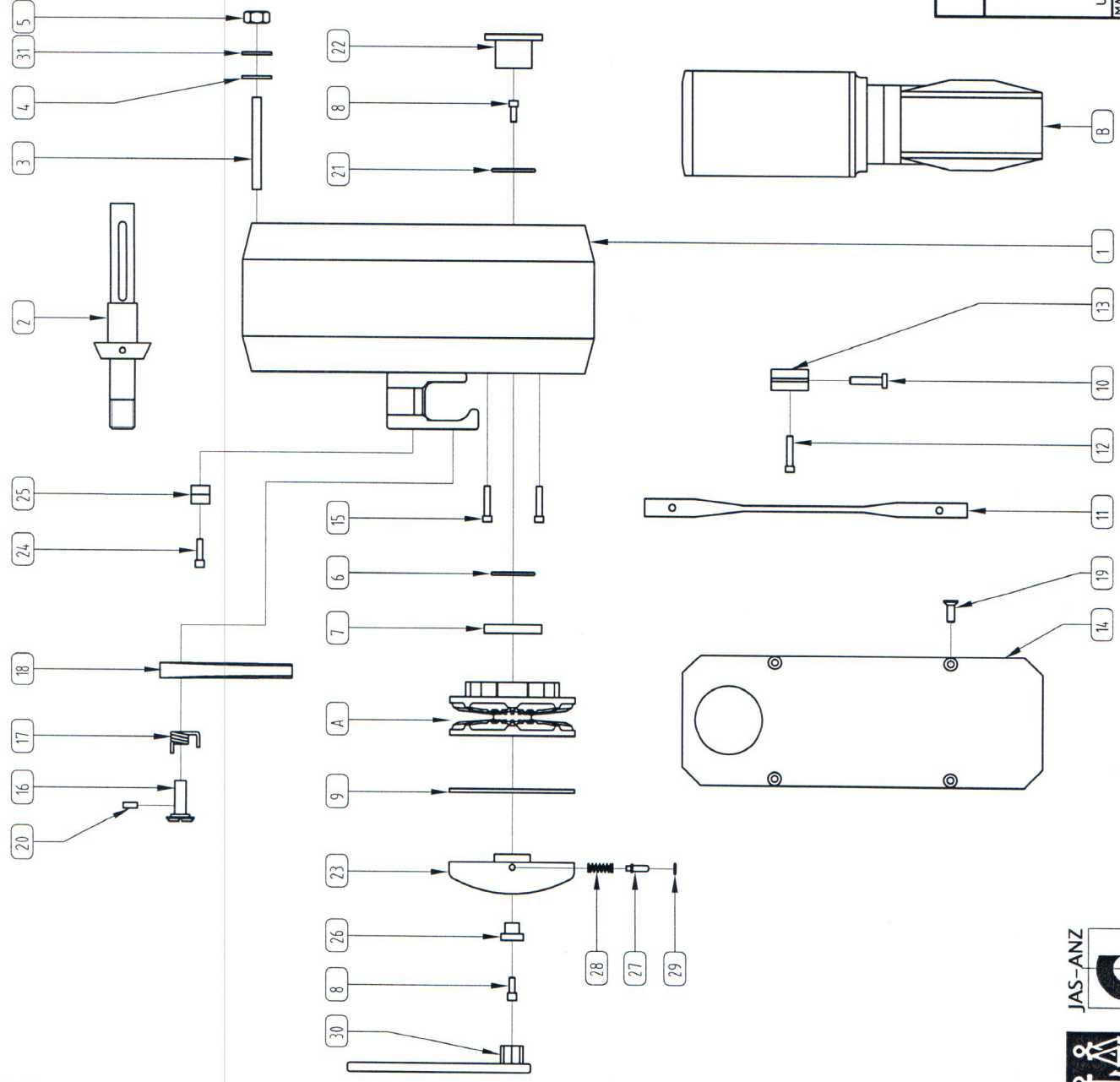
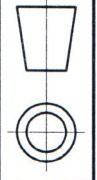

ITEM	PART NUMBER	DESCRIPTION	QTY
1	P22-HSGHFF600	HOUSING ALLOY HFF600 FREEFALL	1
2	K06-SFTH00600C	SHAFT ASSEMBLY H600 COMPACT	1
3	P24-S1D3040600C	STUD SS304 H600C	4
4	S76-30407.94	WASHER SPRING SS304 5/16 INCH	4
5	S20-30407.94	NUT HEX SS304 0-5/16 INCH	4
6	R41-ORG0250201.8	O' RING SEAL 1 X 7/8 X 1/16" (BS020)	1
7	R42-SEA052022.207.9	SEAL 52 X 22 X 8 (TC12828)	1
8	S45-30406.35013	SCREW SHCS SS304 1/4" X 0-1/2" UNC	2
9	P21-NYL100.0032.003	WASHER NYLACAST 96X32X3 MM	1
10	S38-30404.0025.40	SCREW PAN HD SL SS304 3/16 X 1"	1
11	P19-S1R3040700C	STRIPPER SS304 H700C/H600C	1
12	S45-30406.35025	SCREW SHCS SS304 1/4 INCH X 1 INCH	1
13	P05-PLRALL0600C	PEELER ALLOY H600C	1
14	P22-BPLALLH00600	BASE PLATE ALLOY H600 COMPACT	1
15	S45-30406.00025	SCREW SHCS SS304 6MM X 25MM	4
16	P15-PIN30415.88X41	PIN FINGER SS304 H600C	1
17	S36-SPR304FGR0600C	SPRING FINGER H600C	1
18	R40-FGRPVC0600A	FINGER PVC VRC600A	1
19	S33-30404.76013	SCREW CSK SL MT 304 0-3/16 X 0-1/2 INCH	4
20	S35-30406.35006	SCREW GRUB 304 0-1/4 X 0-1/4 INCH	1
21	P21-304025.006.403	WASHER 304 25MM X 1/4" X 1/8"	1
22	R44-PLG25H600C	PLUG H600C	1
23	P07-CLNBRZHFF600	CLUTCH NUT BRONZE HFF600	1
24	S45-30406.35019	SCREW SHCS SS304 1/4 INCH X 0-3/4 INCH	1
25	P13-PWL316HFF600	DECLUTCHER HFF600 FREEFALL	1
26	P21-304019.2007.009	WASHER 304 OD19.2 X ID 7 X 9 LG HFF 600	1
27	P15-PINAB209.52025	PIN- PLUNGER VFF600A	1
28	S36-SPR304VFF600B	SPRING PLUNGER VFF600 ATLANTICS	1
29	R41-ORG00900502.0	O' RING 9 X ID5 X 2MM VFF600 PLUNGER	1
30	F90-HANNYL0600	HANDLE NYLON CLUTCH 600	1
31	S75-30408.0016	WASHER FLAT SS304 5/16" X 5/8"	4

A: GYPSY  
B: MOTOR / GEARBOX ASSEMBLY

<b>WINDLASSES AUSTRALIA</b>	
TITLE HFF600 FREEFALL EXPLODED VIEW	
TOLERANCES (mm) X ± XX ± XXX ±	PART No. K08-FREHFF600 DRN AJN SCALE NTS DATE 06/08/01 APP1 APP2
UNLESS OTHERWISE SPECIFIED MATERIAL	DRG No. K08-FREHFF600 SIZE A4
FINISH	© COPYRIGHT MUIR ENGINEERING PTY. LTD.

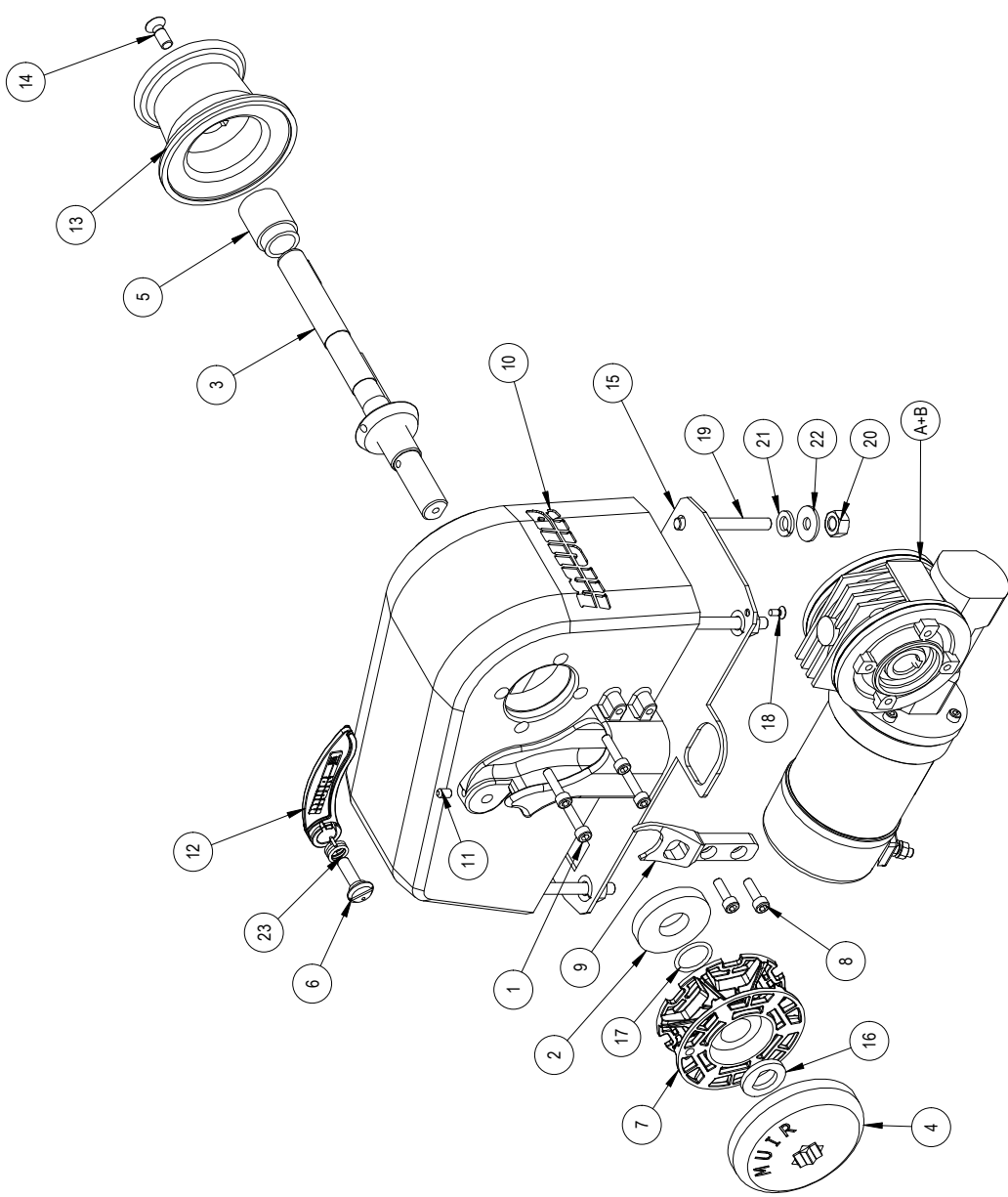

ITEM	QTY	PART NUMBER	DESCRIPTION
1	4	S451039	SCREW SHCS SS316 M6 X 25
2	1	R421013	SEAL 52 X 22 X 8 (TC12828)
3	1	K061282	SHAFT ASSEMBLY HRC650
4	1	P071005	CLUTCH CAP SS316
5	1	P021290	HAT BUSH 19.2x25.2
6	1	P151017	FINGER PAWL PIN
7	1	AS REQUIRED	GYPSY
8	2	S451038	SCREW SHCS SS316 M6 x 20mm
9	1	P051418	PEELER SS316 (CAST)
10	1	P221509	SS 316 HOUSING
11	1	S351011	GRUB SCREW M6 x 10 SS
12	1	R401001	FINGER SS 316
13	1	P041057	CAPSTAN SS316 VC500S
14	1	S331016	SCREW CSK SL MT SS316 8mm x 20mm
15	1	P221510	BASE PLATE
16	1	P231002	D' WASHER SS304
17	1	R411005	O' RING SEAL 1 X 7/8 X 1/16" (BS020)
18	2	S321009	SCREW CSK SS316 4MM X 10MM.
19	4	P241002	STUD SS304 VR/C600A M8 76MM
20	4	S201004	NUT HEX SS304 8MM
21	4	S761005	WASHER SPRING SS304 8MM
22	4	S751007	WASHER FLAT SS304 5/16 X 1"
23	1	S361052	SPRING FINGER

A & B - GBOX & MOTOR

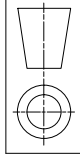

SINCE 1968



**ENGINEERING GROUP PTY. LTD.**

Approval: *P.H.*

LYNX HRC650 SS316 (CAST)  
WITH CAPSTAN

Unless specifically stated otherwise, this drawing is the property of MUIR Engineering Group, and no feature embodied herein may be disclosed, except as previously authorised, in writing, by MUIR Engineering Group.

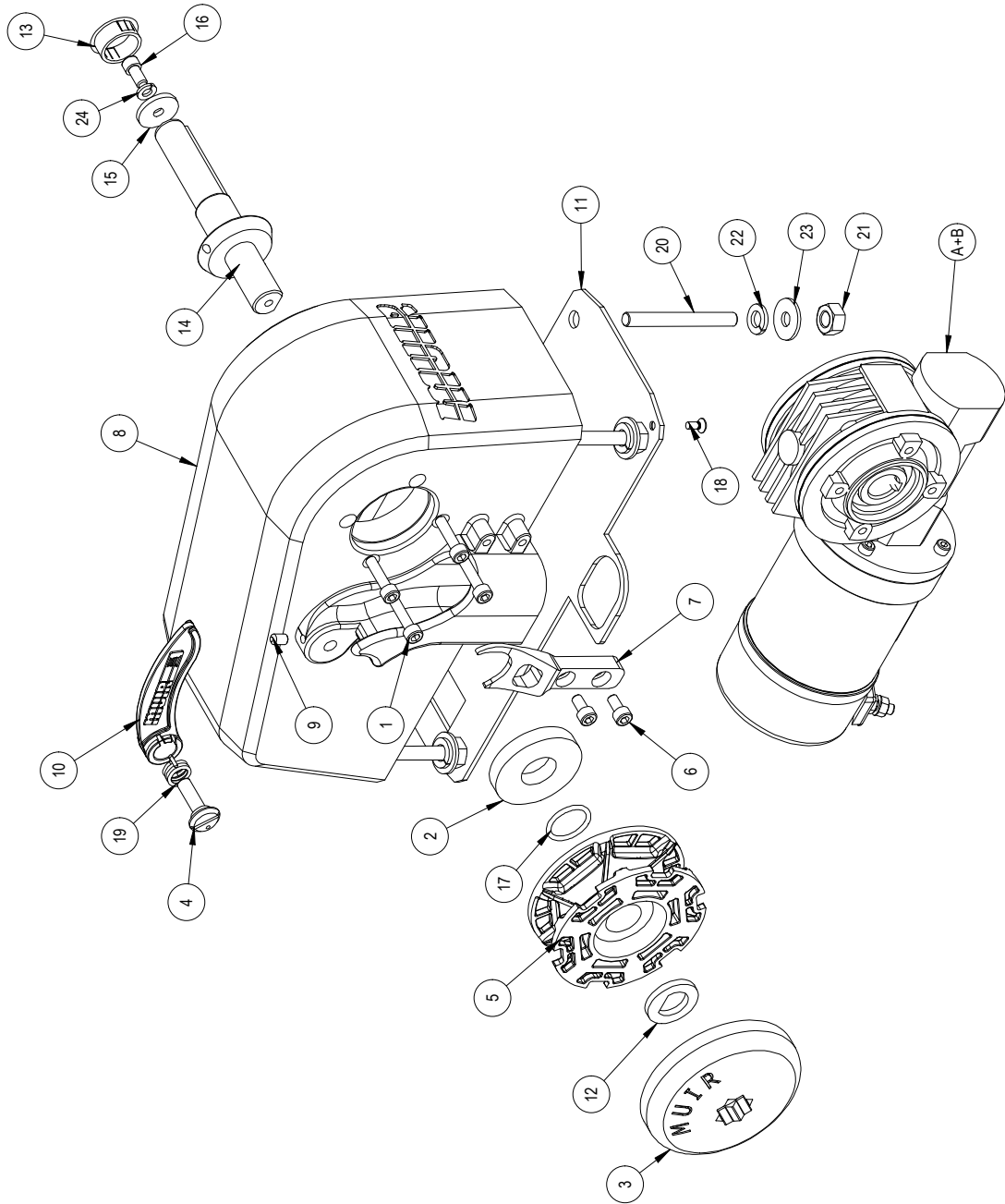

ITEM	QTY	PART NUMBER	DESCRIPTION
1	4	S451039	SCREW SHCS SS316 M6 X 25
2	1	R421013	SEAL 52 X 22 X 8 (TC12828)
3	1	P071005	CLUTCH CAP SS316 VR600/HR650
4	1	P151017	FINGER PAWL PIN
5	1	AS REQUIRED	GYPSY
6	2	S451002	SCREW SHCS SS316 M6 x 12mm
7	1	P051418	PEELER SS316 (CAST)
8	1	P221509	SS 316 HOUSING
9	1	S351011	GRUB SCREW M6 x 10 SS
10	1	R401001	FINGER SS 316
11	1	P221510	BASE PLATE
12	1	P231002	D' WASHER SS304
13	1	R441001	PLUG H600C(DP 1000 DOME PLUG BLK)
14	1	K061058	SHAFT ASSEMBLY H600/HR650 COMPACT
15	1	P211003	WASHER 316 25mm X 1/4" X 1/8"
16	1	S451008	SCREW SHCS SS304 1/4 INCH X 3/4 INCH
17	1	R411005	O' RING SEAL 1 X 7/8 X 1/16" (BS020)
18	2	S321009	SCREW CSK SS316 4mm X 10mm
19	1	S361052	SPRING FINGER
20	4	P241002	STUD SS304 VRC600A M8 76mm
21	4	S201004	NUT HEX SS304 8MM
22	4	S761005	WASHER SPRING SS304 8mm
23	4	S751007	WASHER FLAT SS304 5/16 X 1"
24	1	S761002	WASHER SPRING SS304 6mm

A & B - GBOX & MOTOR

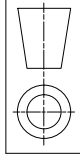

SINCE 1968  
**MUIR**  
 ENGINEERING GROUP PTY. LTD.

Approval: *P.H.*  
 LYNX HR650 SS316 (CAST)

Unless specifically stated otherwise, this drawing is the property of MUIR Engineering Group, and no feature embodied herein may be disclosed, except as previously authorised, in writing, by MUIR Engineering Group.

GYPSY OPTIONS

PART NO.	PATTERN NO.	DESCRIPTION
P101002	116	GYPSY VR600/H600/H806/H650 116 6MM SL/DIN766 SS316 SUIT ROPE 'N' CHAIN
P101066	117	GYPSY VR600/H600/HR650 117 6mm HT/BBB SS316 ALSO SUIT ROPE 'N' CHAIN C/W BRZ INSERT
P101384	115	GYPSY 650 COMPACT 115 8MM HT G4 R/C SS316
P101385	118	GYPSY 650 COMPACT 118 8MM SL R/C SS316

**MAINTENANCE SCHEDULE**

INSTALLATION	DATE	PROCEDURE
At Installation		See page 4/5
6 Months after installation		<ul style="list-style-type: none"> <li>- Check all bolts are tight.</li> <li>- Check Grease tape/anti-corrosion film on Motor /Gear drive</li> </ul>
12 months after installation		Remove chain wheel, clean cones then fully grease and lubricate. <ul style="list-style-type: none"> <li>- see Maintenance &amp; Servicing</li> </ul>
2 years after installation		Remove chain wheel, clean cones then fully grease and lubricate. <ul style="list-style-type: none"> <li>- see Maintenance &amp; Servicing</li> </ul>
3 years after installation		Remove chain wheel, clean cones then fully grease and lubricate. <ul style="list-style-type: none"> <li>- see Maintenance &amp; Servicing</li> </ul>
4 years after installation		Full winch Service <ul style="list-style-type: none"> <li>- All of the above</li> <li>- Drain and replace gearbox oil with 320 grade gear oil</li> </ul>

## Warranty Limited for period of Three years (First Owner)

We warrant each new product manufactured by us to be free from defects in material and workmanship for a period of 3 years (first Owner).

This warranty shall become effective only upon receipt of a completed warranty registration, which shall identify the product so registered by serial number. This warranty shall remain in effect for a period of three (3) years from the date of purchase.

**For vessels in charter or hire the warranty is one (1) year due to various operators and overloading which may occur.**

### Conditions

While this warranty applies to defects in material and workmanship, it does not apply to:

- Normal worn parts or damage caused by neglect, lack of maintenance, accident or improper service/installation or service by persons other than an authorised Muir representative.
- Muir shall not be responsible for failures due to products being used in applications that are not intended for or exceed the products performance specifications.
- For warranty claim, defective product must be returned to Muir for inspection.
- Muir will not be responsible for freight charges, removal or installation labour on warranty claims.
- Damage due to unsatisfactory storage or use of equipment prior to installation in the approved/intended manner.

### Exclusions

Warranty is limited to twelve months for:

- Electric motors / controls / equipment
- Hydraulic pumps / controls / valves
- Weather seals
- Use on charter/hire/commercial boats

All incidental and/or consequential damages are excluded from this warranty. Warranties of merchantability and fitness are excluded from this warranty. Implied warranties are limited to the life of this warranty. Some countries do not allow limitations on how long an implied warranty lasts or the exclusion or limitation of incidental or consequential damages, so the above may not apply to you.

**We reserve the right to improve the design or materials used on any product without assuming any obligation to modify any product previously manufactured or used.**

### Liability

Muir Engineering liability under this warranty shall be to the exclusion of all other warranties or liabilities (to the extent permitted by law). In particular (but without limitation):

Muir Engineering shall not be liable for:

Any indirect or consequential loss including (without limitation) any loss of anticipated profits, damage to reputation or goodwill, loss of expected future business, damages, costs or expenses payable to any third party or any other indirect losses. Any damage to yachts or equipment. Death or personal Injury (unless caused by Muir Engineering negligence).

**Please visit our website for more information and to register your product: <https://muir.com.au/support/warranty/>**







SCAN FOR MUIR WARRANTY







**Head Office:**

100 Browns Road  
Kingston, Tasmania  
Australia, 7050  
Int Tel: +61 03 62290600  
Email: [info@muir.com.au](mailto:info@muir.com.au)  
[www.muir.com.au](http://www.muir.com.au)

**Windlass:**

**Serial Number:**

Copyright 2023 Muir Engineering Group Pty Ltd.

Muir reserves the right to alter specifications without notice. All rights reserved.

While all care and attention has been taken in the preparation of this Manual, no responsibility shall be taken for error and omissions.



**BUILT TO LAST SINCE 1968**

